

This box contains:

Codec C60

Top tray

TRC V remote control

- A. Rack profiles (2 pcs)
- B. Rack rear brackets (2 pcs)
- C. Rack extension brackets (2 pcs)
- D. Rack ear profiles (2 pcs)

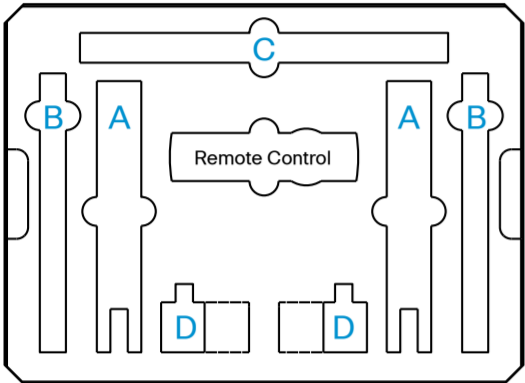

Accessories box and cable kit

- HDMI cable (3 m / 10 ft)
- Ethernet cable (5 m / 16 ft)
- Power cable (1.8 m / 6 ft)
- Batteries LR03 AAA 1.5 V for the remote control
- Screwdriver, combi 2 mm / 4 mm Allen Key (unbraco)
- Screws (M6 and M3) and cage nuts (M6)
- Universal rack brackets*

* Universal rack brackets: Use these only if the supplied rail based rack mounting kit does not fit your type of rack.

User guides

The user documentation for this product, including compliance and safety information, is available on the Cisco web site. Go to: <http://www.cisco.com/go/telepresence/docs>.

Rack mounting

WARRANTY: Rack mounting the codec without using the supplied mounting kit will void the warranty.

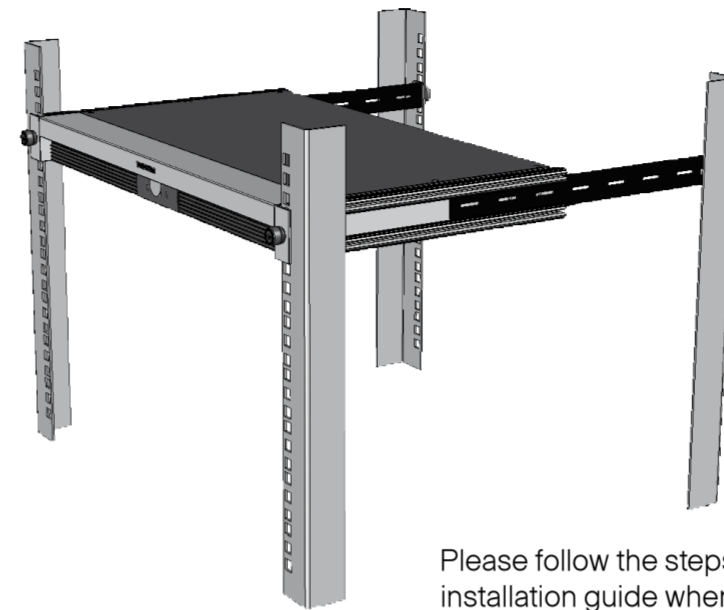

Please follow the steps in this installation guide when rack mounting the codec.

TIP

If the menu is not already present, press Home key or OK key on the remote control to open the menu. Navigate in the menu with the arrow keys.



Rack mounting and connecting cables

1 Assembling the rack profiles

Slide the rack profiles A and B together.

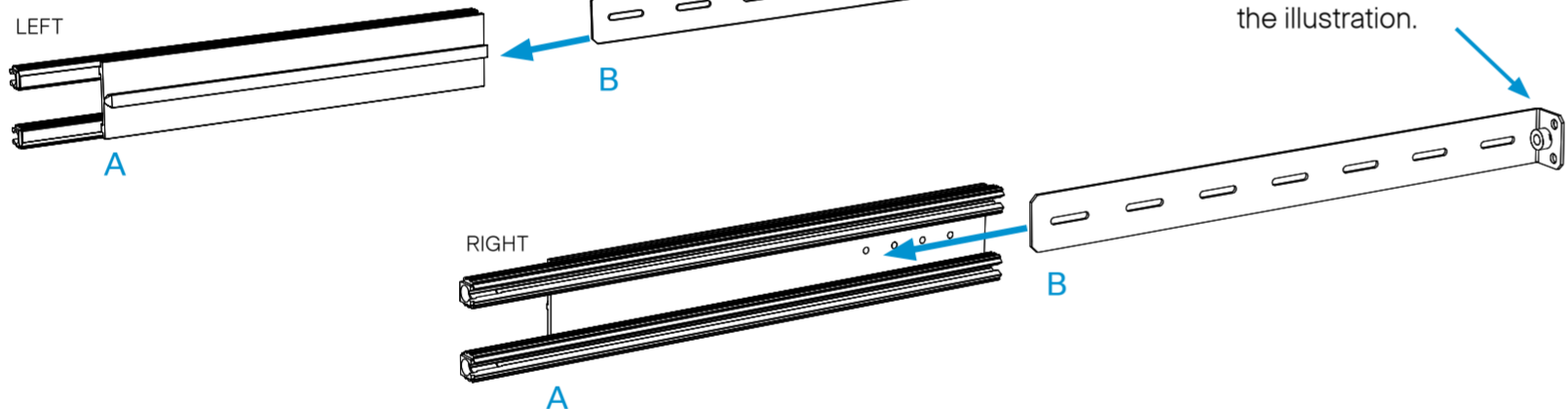

2 Optional: Assembling the extension rails

If the rack is deeper than the length of the rack profiles A+B, then the extension rails C are needed.

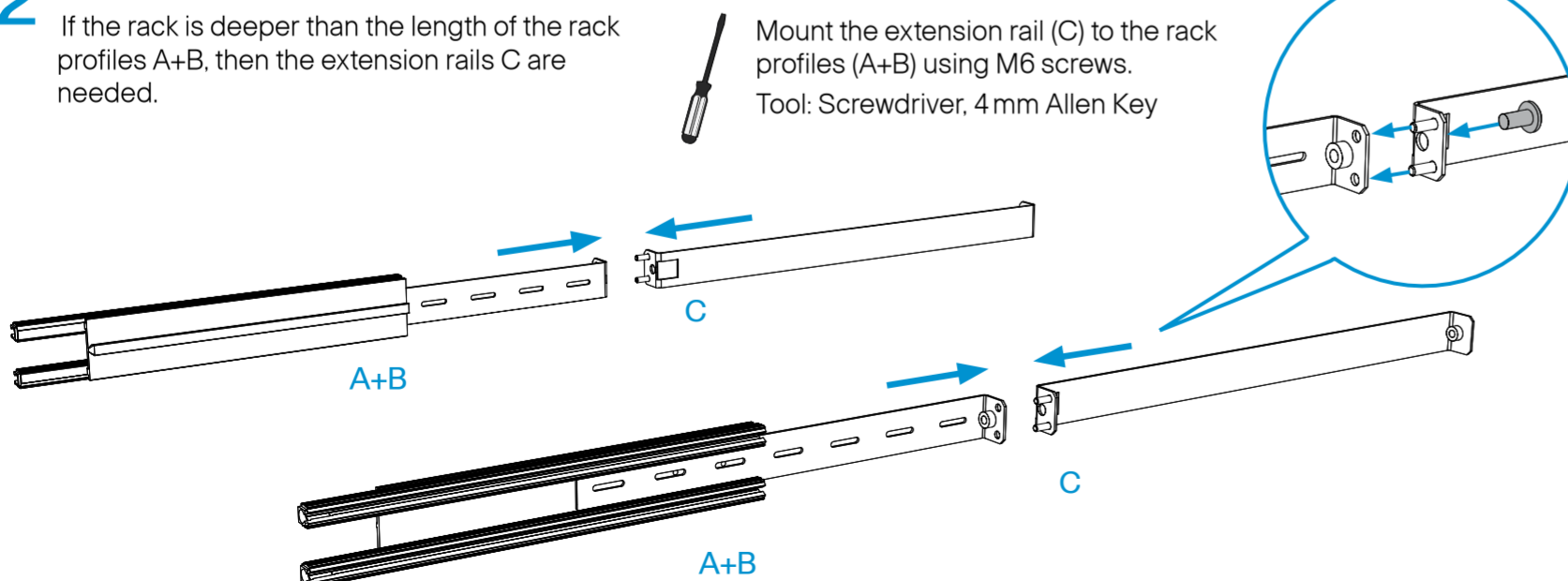

3 Mounting the rack profiles to the rack

Mount the left and right rack profiles A+B(+C) to the rack. The screws, screwdriver and cage nuts are found in the accessories box.

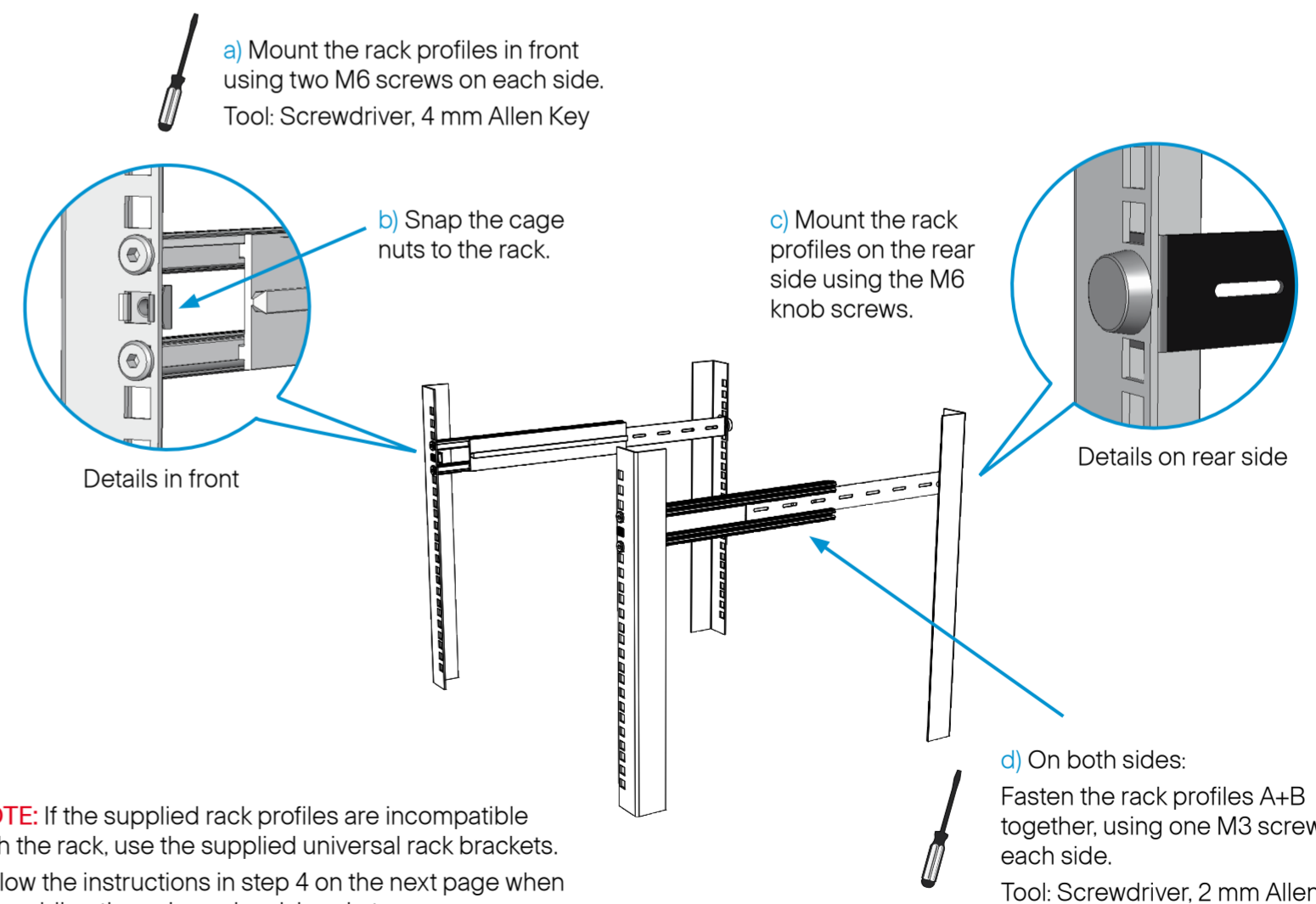

4 Assembling the rack ear profiles

Mount the rack ear profiles to the codec.

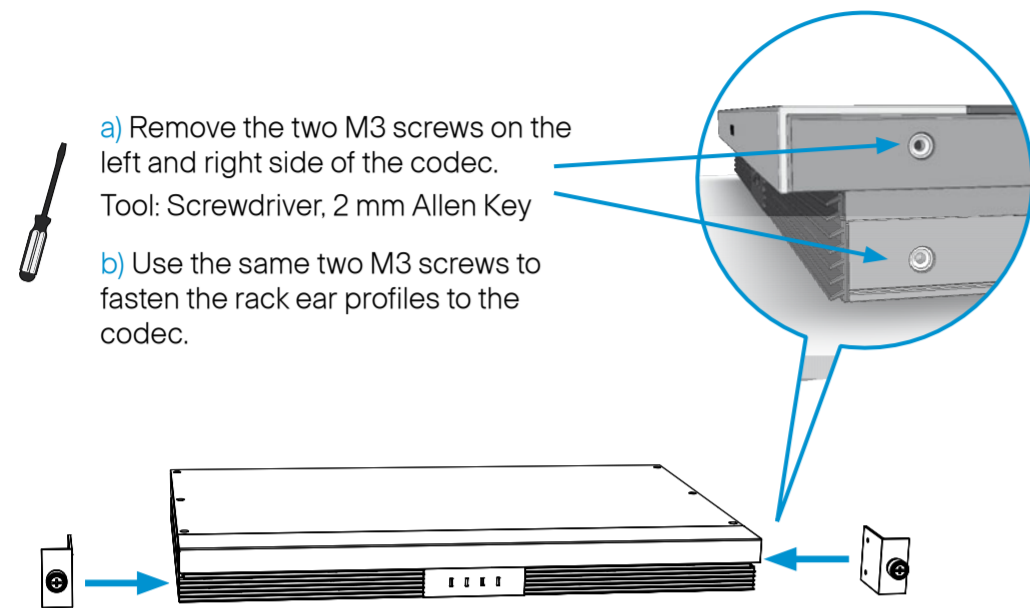

- a) Remove the two M3 screws on the left and right side of the codec.
Tool: Screwdriver, 2 mm Allen Key
- b) Use the same two M3 screws to fasten the rack ear profiles to the codec.

5 Mounting the codec onto the rack

Locate the rails and carefully slide the codec onto the rack.

- a) Locate the rails on the codec and the rails on the rack. Lift the codec towards the rack and make sure the codec enter the rails. Carefully slide the codec into the rack.

- b) Fasten the codec in front by tightening the screws on the rack ear profiles.

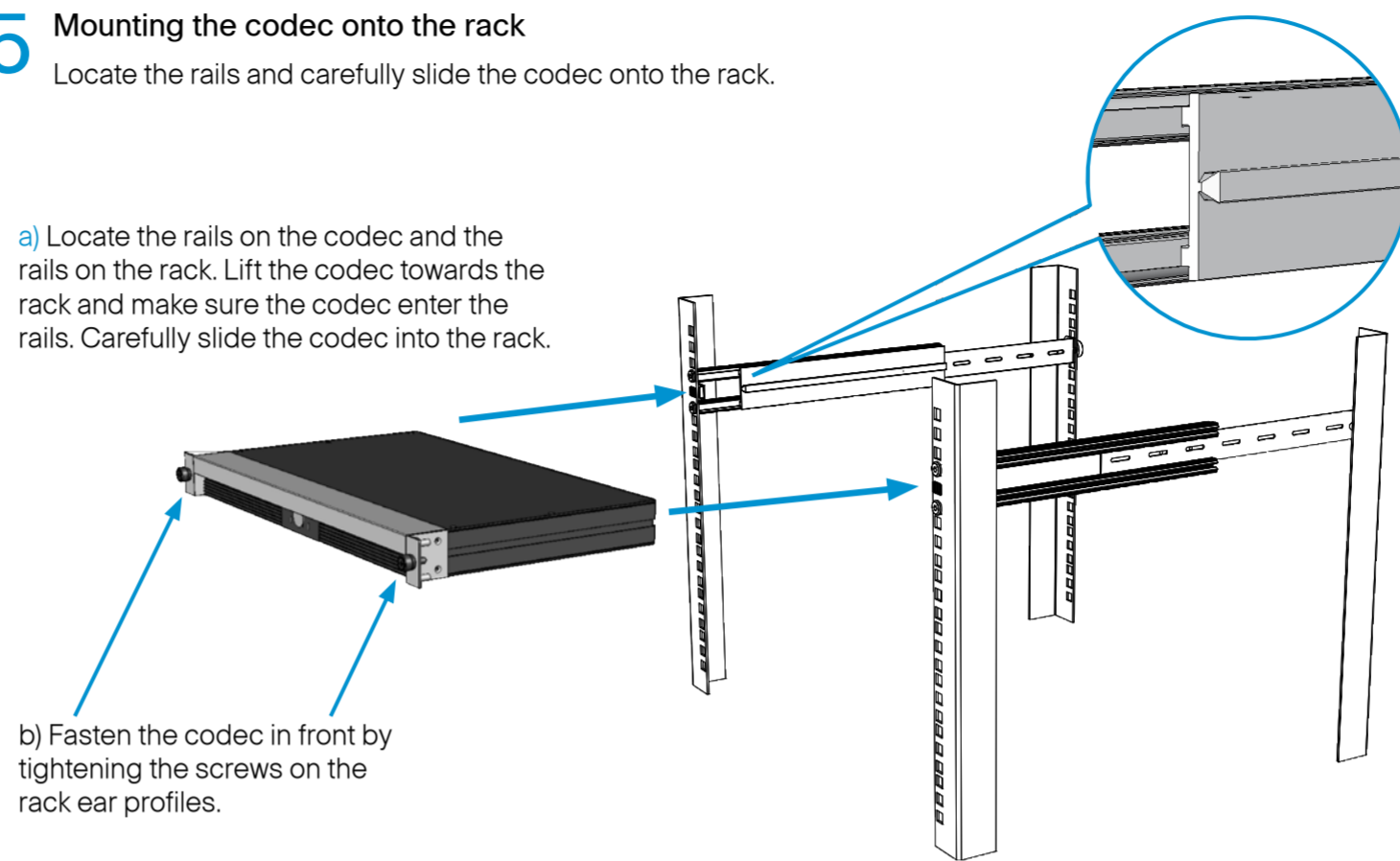

IMPORTANT

There should always be a distance of minimum 10 cm / 4 in. free space in front of the codec.

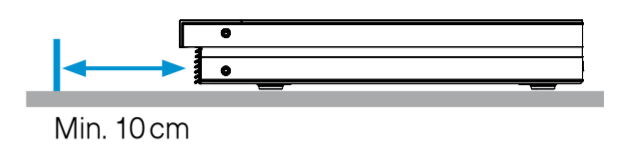

SAFETY REQUIREMENT

Make sure the codec is not mounted with the front side up or down.



6 Connecting cables

The C60 codec offers a great flexibility in connecting audio and video equipment to the system.

For a basic setup, you should go through these steps:

1. Connect the main camera to the HDMI 1 input using a HDMI to HDMI cable
 - For camera control you should also connect the camera to the Camera Control input using the dedicated cable that came with your camera (RJ45 to DSUB)
2. Connect the monitor display to the HDMI 1 output using a HDMI to HDMI cable
3. If you want to send images from a PC, connect the PC to the DVI-I 3 input, using a DVI to DVI or a HDMI to DVI cable (for digital signals) or VGA to DVI cable (for analog signals) depending on your PC's capabilities
 - Audio from the PC could be connected to Line 1 and 2 inputs for stereo signals
4. Connect the microphone to the XLR input
5. The loudspeakers should be connected to Line 1 and 2 outputs
6. Connect the codec to the IP network using the Ethernet 1 interface
7. Connect the power and use the power switch to turn the codec on

NOTE: If using the DVI-I out 2 for the main monitor a shortcut is required to move the on screen display (OSD) to this output. On the remote control key in the following sequence:

- Disconnect - * - # - * - # - 0 - 2 - #

Basic setup - The main connectors are highlighted in orange color.

